



Advanced Card Systems Ltd.
Card & Reader Technologies

ACR38U PocketMate

Smart Card Reader

FIPS 201 Certified



Technical Specifications V1.08



Table of Contents

1.0.	Introduction	3
1.1.	Smart Card Reader.....	3
1.2.	Ingenious Design	3
1.3.	Ease of Integration.....	3
2.0.	Features	4
3.0.	Supported Card Types	5
3.1.	MCU Cards	5
3.2.	Memory-based Smart Cards.....	5
4.0.	Typical Applications.....	6
5.0.	Technical Specifications.....	7



1.0. Introduction

ACR38U PocketMate is a smart card reader that has more to it than meets the eye. As small and elegant looking as it is, this smart card reader is capable of supporting demanding smart card applications using full-sized contact smart cards. It provides the perfect balance between reliable functionality and design aesthetics to meet your security needs in many fields, including e-Banking, e-Payment, and e-Government.

1.1. Smart Card Reader

ACR38U PocketMate supports ISO 7816 Class A, B, and C smart cards (5 V, 3 V, and 1.8 V) and microprocessor cards with the T=0, T=1 protocol. In addition, it supports a wide variety of memory cards in the market, including the Department of Defense Common Access Card (CAC). This makes it ideal for a broad range of solutions, such as PIV Application, Physical and Logical Access Control, Digital Signature, and Online Banking.

It connects with computers through its USB Full Speed interface and has a smart card read/write speed of 344 Kbps. This small device proves to be a powerful smart card reader as it houses the ACR38 core, which has been proven to support highly demanding smart card applications.



1.2. Ingenious Design

The highly compact ACR38U PocketMate is specifically designed to be brought and used anytime, anywhere. No larger than a standard USB token, it transforms into a smart card reader for full-sized contact smart cards with just a single swivel motion.

1.3. Ease of Integration

Being a PC/SC and CCID compliant device, ACR38U PocketMate can easily be integrated in a PC environment. Its drivers are compatible with Windows, Linux and Mac operating systems. In addition, ACR38U PocketMate may now be used on mobile devices running the Android™ platform with versions 3.1 and above.

With its various features, the FIPS 201 certified smart card reader is the perfect smart card reader for your smart card solution.



2.0. Features

- USB 2.0 Full Speed Interface
- Plug-and-Play – CCID support brings utmost mobility
- Swivel Motion Design
- Smart Card Reader:
 - Supports ISO 7816 Class A, B and C (5 V, 3 V, 1.8 V) cards
 - Supports CAC (Common Access Card)
 - Supports microprocessor cards with T=0 and T=1 protocol
 - Supports memory cards
 - Supports PPS (Protocol and Parameters Selection)
 - Features Short Circuit Protection
- Application Programming Interface:
 - Supports PC/SC
 - Supports CT-API (through wrapper on top of PC/SC)
- Supports Android™ OS 3.1 and above
- Compliant with the following standards:
 - FIPS 201
 - TAA
 - EN60950/IEC 60950
 - ISO 7816
 - CE
 - FCC
 - VCCI
 - PC/SC
 - CCID
 - EMV 2000 Level 1
 - Microsoft WHQL
 - RoHS



3.0. Supported Card Types

3.1. MCU Cards

ACR38U PocketMate operates with MCU cards following either the T=0 or T=1 protocol. It also works with CAC cards, ideal for US PIV and PKI applications.

3.2. Memory-based Smart Cards

ACR38U PocketMate works with several memory-based smart cards such as:

- Cards following the I2C bus protocol (free memory cards) with maximum 128 bytes page with capability, including:
 - Atmel: AT24C01/02/04/08/16/32/64/128/256/512/1024
 - SGS-Thomson: ST14C02C, ST14C04C
 - Gemplus: GFM1K, GFM2K, GFM4K, GFM8K
- Cards with secure memory IC with password and authentication, including:
 - Atmel: AT88SC153 and AT88SC1608
- Cards with intelligent 1k bytes EEPROM with write-protect function, including:
 - Infineon: SLE4418, SLE4428, SLE5518 and SLE5528
- Cards with intelligent 256 bytes EEPROM with write-protect function, including:
 - Infineon: SLE4432, SLE4442, SLE5532 and SLE5542
- Cards with '104' type EEPROM non-reloadable token counter cards, including:
 - Infineon: SLE4406, SLE4436, SLE5536 and SLE6636
- Cards with Intelligent 416-Bit EEPROM with internal PIN check, including:
 - Infineon: SLE4404
- Cards with Security Logic with Application Zone(s), including:
 - Atmel: AT88SC101, AT88SC102 and AT88SC1003



4.0. Typical Applications

- e-Government
- e-Banking and e-Payment
- e-Healthcare
- Public Key Infrastructure
- Network Security
- Access Control
- Loyalty Program



5.0. Technical Specifications

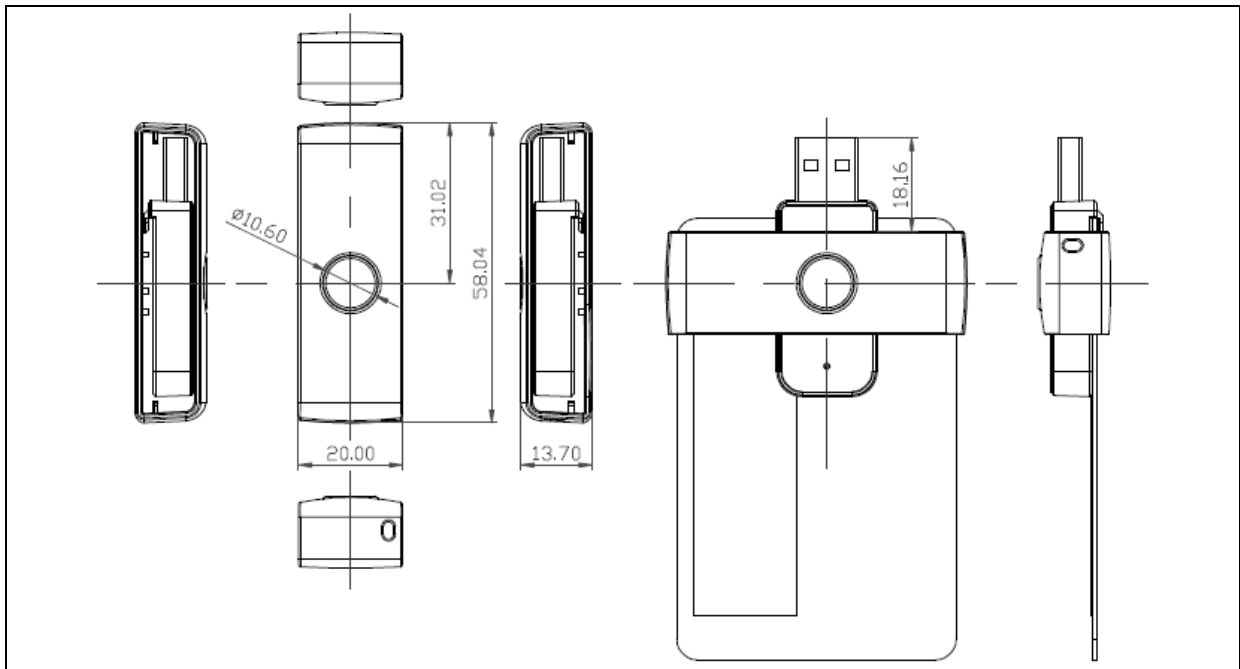

Universal Serial Bus Interface

Type USB Full Speed, four lines: +5 V, GND, D+ and D-
Power Source From USB
Speed 12 Mbps

Smart Card Interface

Standard ISO 7816 Class A, B and C (5 V, 3 V, 1.8 V), T=0 and T=1
Supply Current max. 50 mA
Smart Card Read/Write Speed max. 344,086 bps
Short Circuit Protection +5 V/GND on all pins
CLK Frequency 4 MHz
Card Connector Contact
Card Insertion Cycles min. 100,000

Physical Specifications

Dimensions 58.0 mm (L) x 20.0 mm (W) x 13.7 mm (H)
Color Black
Weight 12 g

Operating Conditions

Temperature 0 – 50 °C
Humidity 10% - 90%
MTBF 500,000 hrs.

Application Programming Interface

PC/SC
CT-API (through wrapper on top of PC/SC)

Certifications/Compliance

EN60950/IEC 60950, ISO 7816, FIPS 201, TAA, CE, FCC, VCCI, PC/SC, CCID, EMV 2000 Level 1, RoHS, USB Full Speed
Microsoft® WHQL 2000, XP, Vista, 7, 8, Server 2003, Server 2008, Server 2008 R2, Server 2012

Device Driver Operating System Support

Windows® CE, 98, ME, 2000, XP, Vista, 7, 8, Server 2003, Server 2003 R2, Server 2008, Server 2008 R2, Server 2012
Linux, Mac, Android™ 3.1 and above

